

VCE 50 Wet

Zeichng.-Nr. 533684 - Blatt1 Datum 06-2024

Drawing-no. 533684 - page1 date 06-2024

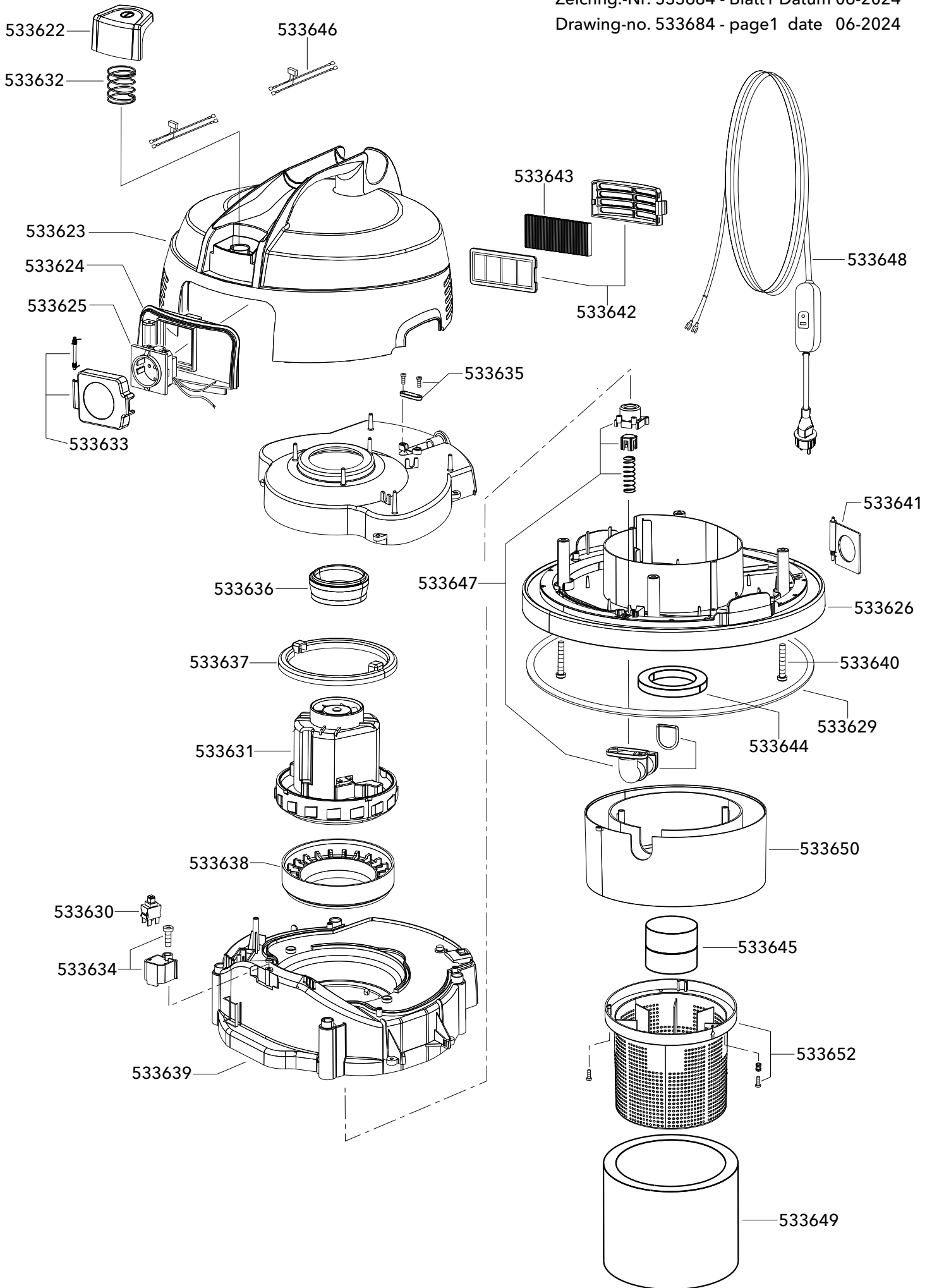

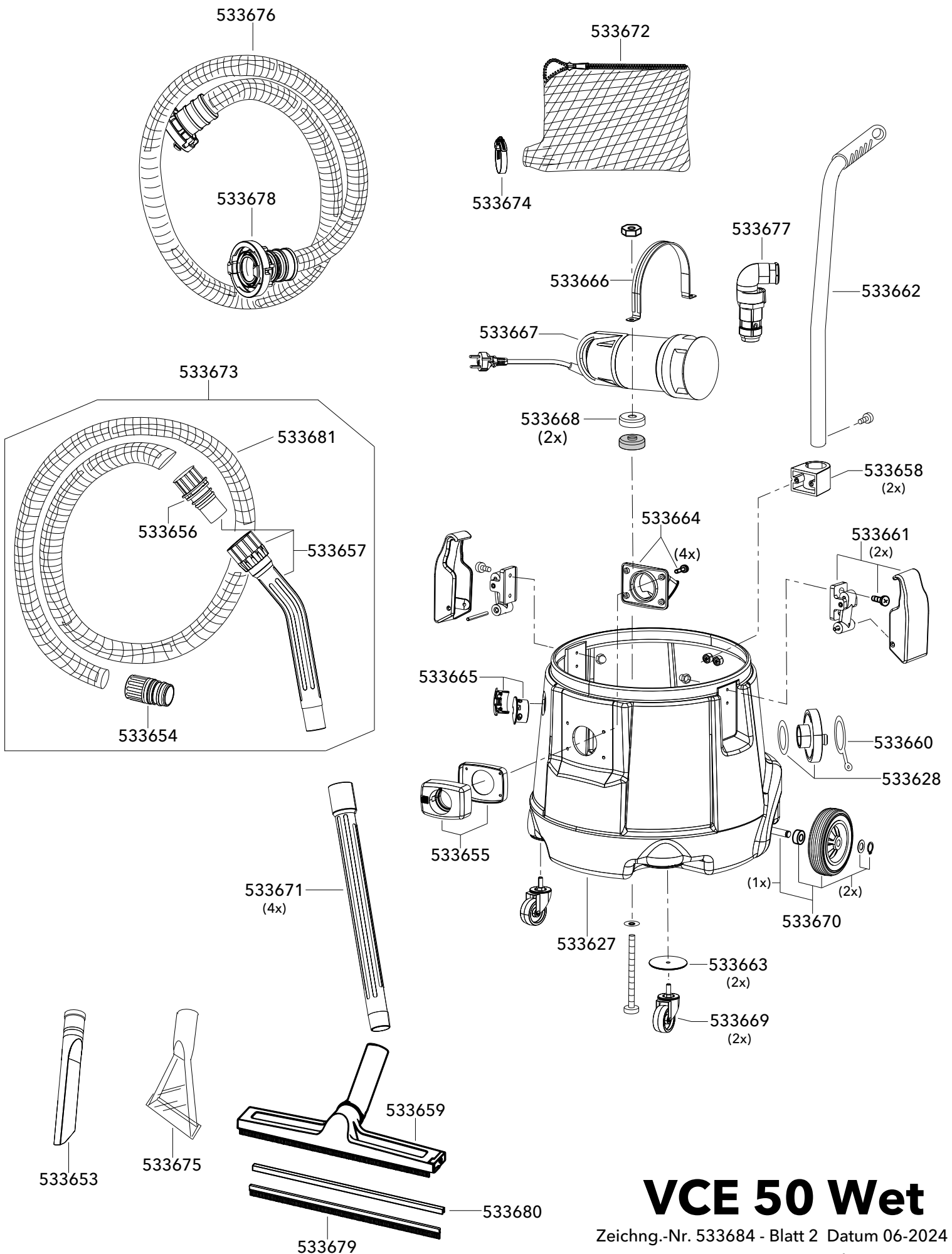

VCE 50 Wet

Zeichng.-Nr. 533684 - Blatt 2 Datum 06-2024

Drawing-no. 533684 - page 2 date 06-2024